

HLC 槓桿油壓缸 FCM 法蘭型油路板附調速

Flange type manifold with flow control



Hydraulic lever-type Cylinder FCM

• Bore: $\phi 25$ - $\phi 63$ mm • Pmax: 70kg/cm²

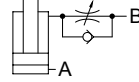
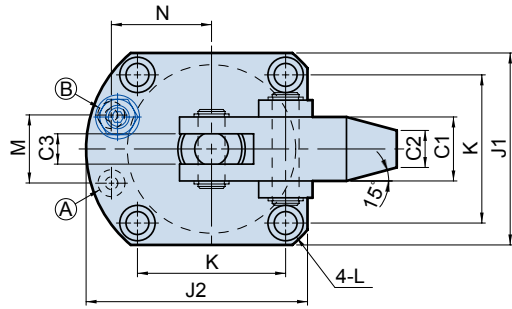

- (A) 夾持油孔
Clamping Port
- (B) 放鬆油孔
Unclamping Port



HLC-FCM Bore -L

HLC-FCM Bore -R

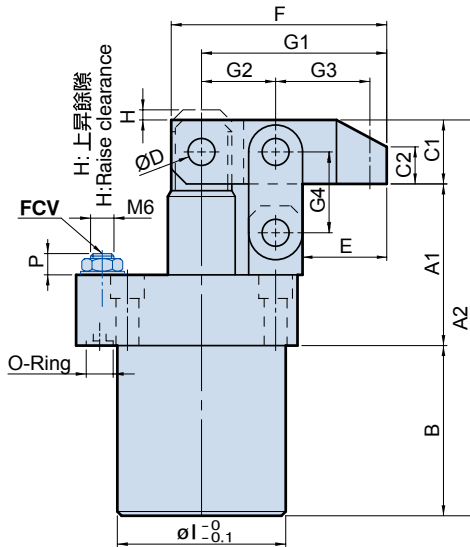

Dimensional table

UNIT:mm

ITEM	MODEL	HLC-FCM25	HLC-FCM32	HLC-FCM40	HLC-FCM50	HLC-FCM63
A1		49	52	57	67	77
A2		122	131	144.2	162.4	186.8
B		54	60	65	70	78
C1		□19	□19	□22.2	□25.4	□31.8
C2		11	11	13	15	19
C3		9	9	10	11	15
ϕD		8	8	10	12	15
E		25	25	30	35.5	43
F		64	64	77	90	110
G1		55	55	66	77	94
G2		22	22	26	30	36
G3		28	28	34	39	48
G4		24	24	29	33	39
H		3	3	4	4	4
ϕl		$\phi 45$	$\phi 50$	$\phi 58$	$\phi 68$	$\phi 81$
J1		55	57	69	75	96
J2		64	65.5	79	87	112
K		42	44	52	58	75
L		$\phi 6.8$ - $\phi 10.5$ x6.5D.	$\phi 6.8$ - $\phi 10.5$ x6.5D.	$\phi 9$ - $\phi 14$ x9D.	$\phi 9$ - $\phi 14$ x9D.	$\phi 11$ - $\phi 17$ x11D.
M		20	22	26	30	36
N		28	29	34.5	39	50
O-Ring		P6	P6	P9	P9	P9
P Min.		7.1	4.1	4.1	3.6	3.6
P Max.		10.2	8.1	8.1	7.6	7.6